

BEHIND THE WALL (BTW)

Urine-Diverting Conveyor Toilet



Zion National Park, UT



The environmentally-compliant Toilet Tech BTW conveyor is the superior choice for waste management in the North American Backcountry. The BTW separates liquid and solid waste at the source, reducing odor, maintenance load, and operator exposure to hazardous waste. It has been proven at hundreds of locations, from rocky alpine terrain to barren desert.

- Self-sustaining & hassle-free
- Reliable & low-maintenance materials (stainless steel)
- >99% diversion of liquid waste
- Significant odor reduction
- No bulking agent required
- Gains compliance over pit toilets



Mt. Rainier National Park, WA



Mt. Rainier National Park, WA



Smith Rock State Park, OR



Design

Separating liquid waste from solid waste is the key to easy, low-cost management of human waste in remote areas. The BTW toilet achieves >99% urine diversion using an inclined conveyor belt with a foot pedal flush mechanism. Liquids run down to the front of the conveyor and into a tray, then plumbed into a urine dispersion field and absorbed by native plants. Solids move along the conveyor when the foot pedal is pumped, eventually falling into one of two types of waste vaults - the decompose vault (DCV) or a solid waste container depending on the system in place.

BTW conveyors are available in Short (15" belt) and Medium (30" belt) sizes. From the user's perspective, this toilet is no different from a standard flush toilet—aside from the fact that the “flush” is achieved by pumping a foot pedal.

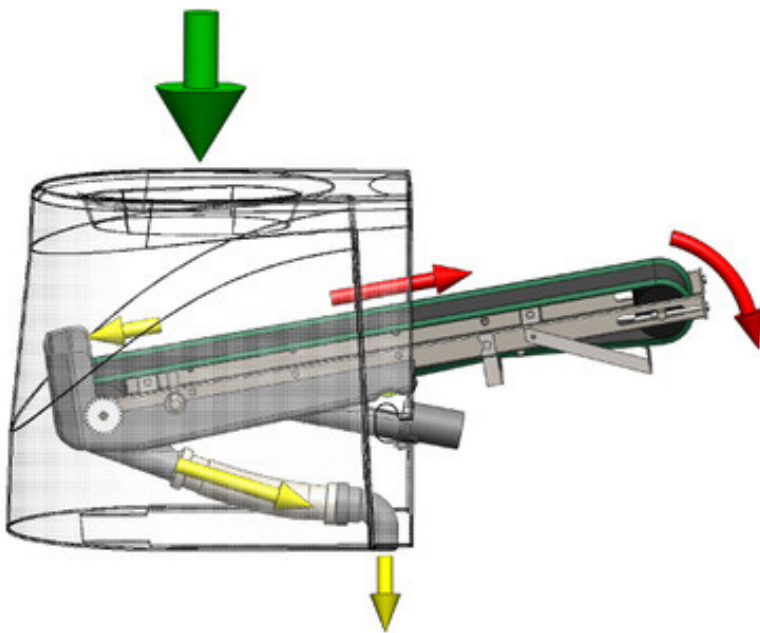

TST TOILET TECH SOLUTIONS

www.TOILETTECH.com

FLUSH  5x



Camp Tamarack, OR

Materials

The BTW toilet is built exclusively with stainless steel, high quality plastic, and a long-lasting rubber conveyor belt. It will not rust or corrode. With hundreds of units in operation for many years, there have been very few part failures and malfunctions. The units are robust and built by hand in France. There are three small wear parts that are recommended to be replaced after many uses (100,000+) or preventatively every 3-5 years.

Maintenance

The frequency of maintenance depends on the volume of users and type of use. A few maintenance trips per year is often sufficient – sometimes even less at low-use sites.

Recommended **quarterly** maintenance:

- Removing, cleaning, and reinstalling the urine tray. This ensures there is no long-term build up of solids that might inhibit urine flow.
- Leak-test the plumbing.
- Cleaning debris from the belt scrapers at the rear of the BTW unit.

Recommended **annual** maintenance:

- Raking and wetting down the solid waste pile to encourage decomposition.
- Cleaning the urine plumbing with microbial enzyme drain cleaner.

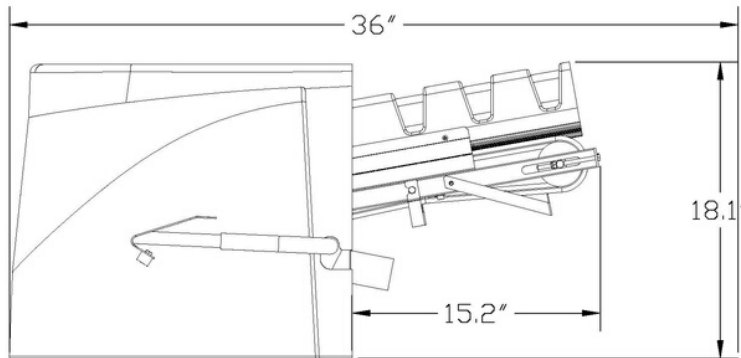
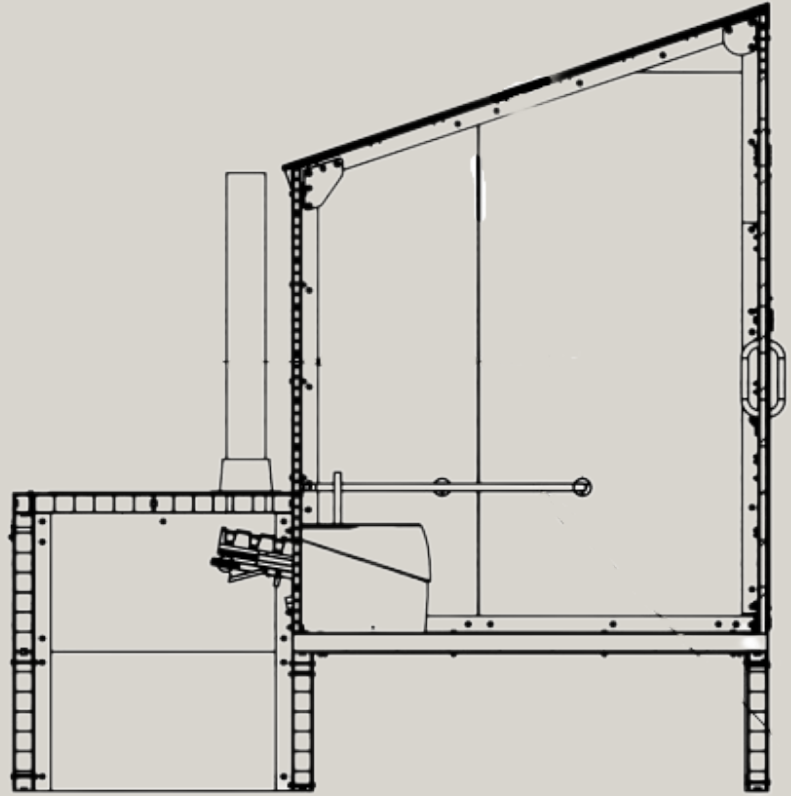

TTS SHORT CONVEYOR

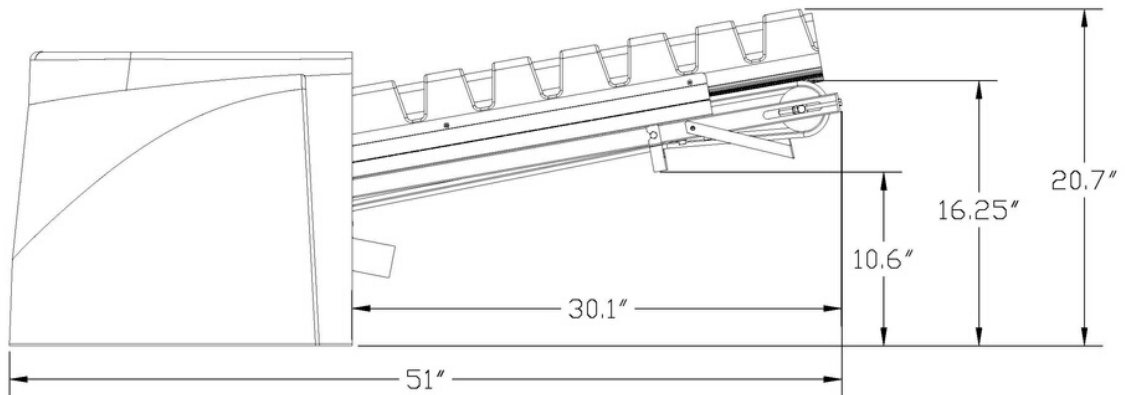

TTS MEDIUM CONVEYOR

NO	REVISION

PROPRIETARY INFORMATION
This drawing is the property of TTS and shall not be used, copied or reproduced in whole or in part, nor shall the contents be revealed in any manner to anyone unless written permission is obtained from Toilet Tech Solutions, Inc.

UNFINISHED DIMENSIONS SPECIFIED:
 2 PLACE DECIMALS #XXX.X
 3 PLACE DECIMALS #XXX.XXX
 FRACTIONS 1/16 INCHES UP

THIRD ANGLE PROJECTION

ALL DIMS ARE IN INCHES
DO NOT SCALE DRAWING



DRWN: RDM	SIZE: B	TITLE: TTS SHORT AND MEDIUM CONVEYOR SIDE VIEW
CHKD: .	PROJECT: 269	SHT: 4 OF 4
DATE: 03 AUG 2018	DWG. NO: 269-90 R&D	REV: -
SCALE: NTS		